

PARÇA KODU PART CODE	PARÇA ADI PART NAME	ERKEK TERMINAL MALE TERMINAL	a ÖLÇÜSÜ (AYAR) a MEASURE (SET)	Malzeme Material	Kaplama Coating
TD 2166.50 DP	KİLİTLİ DİŞİ FİŞ 4.8 KISA TİP 0,50 M.A.=DP=	0.50	0.35±0.1	(CuZn30) Piring / Brass	_____
TD 2166.50 RP	KİLİTLİ DİŞİ FİŞ 4.8 KISA TİP 0,50 M.A.=RP=	0.50	0.35±0.1	(CuZn30) Piring / Brass	_____
TD 2166.50 RPK	KİLİTLİ DİŞİ FİŞ 4.8 KISA TİP 0,50 M.A.=RPK=	0.50	0.35±0.1	(CuZn30) Piring / Brass	Kalay / Sn (2-6µ)
TD 2166.50 RÇN	KİLİTLİ DİŞİ FİŞ 4.8 KISA TİP 0,50 M.A.=RÇN=	0.50	0.35±0.1	Nikel kaplı çelik / Nickel plated Steel	Nikel / Ni (>1.5µ)
TD 2166.80 RP	KİLİTLİ DİŞİ FİŞ 4.8 KISA TİP 0,80 M.A.=RP=	0.80	0.55±0.1	(CuZn30) Piring / Brass	_____
TD 2166.80 RPK	KİLİTLİ DİŞİ FİŞ 4.8 KISA TİP 0,80 M.A.=RPK=	0.80	0.55±0.1	(CuZn30) Piring / Brass	Kalay / Sn (2-6µ)
TD 2166.80 RÇN	KİLİTLİ DİŞİ FİŞ 4.8 KISA TİP 0,80 M.A.=RÇN=	0.80	0.55±0.1	Nikel kaplı çelik / Nickel plated Steel	Nikel / Ni (>1.5µ)

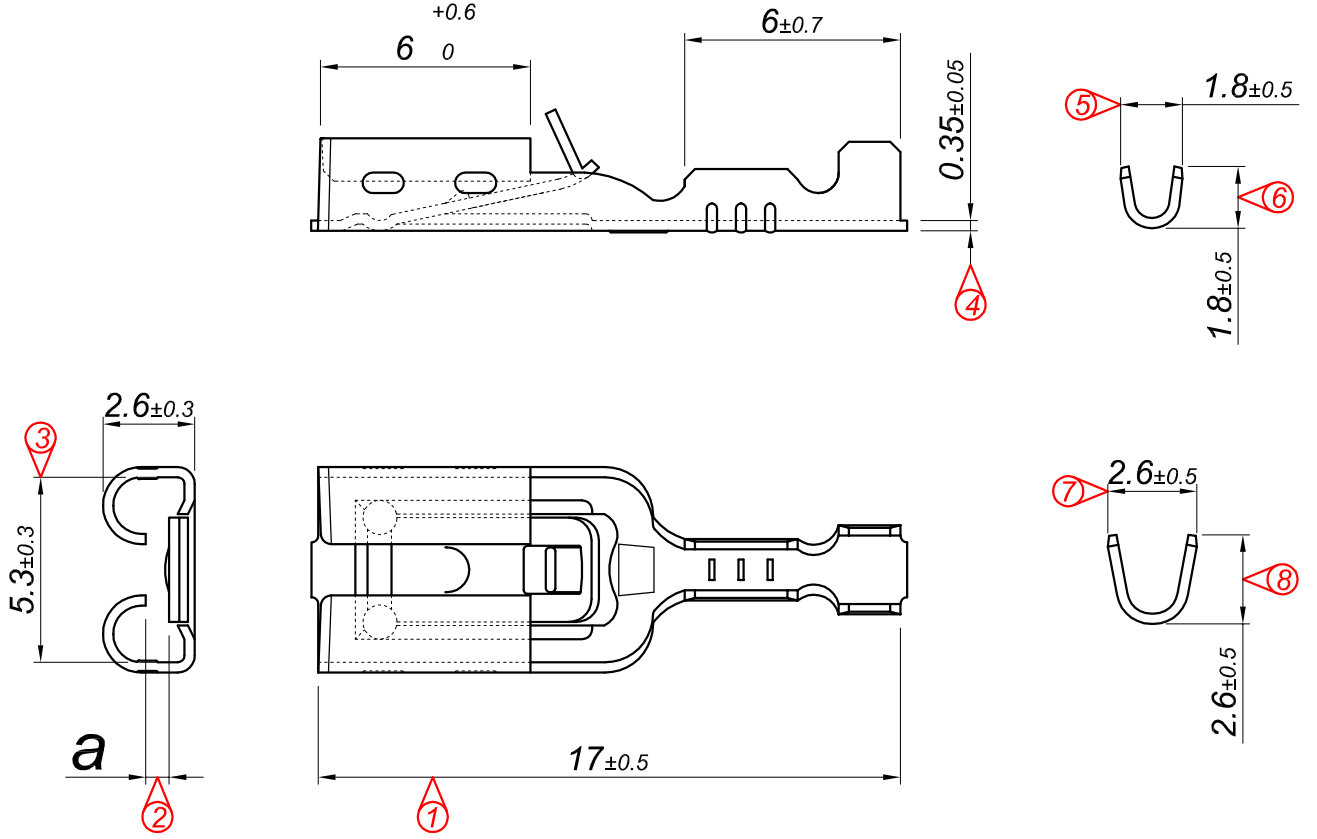

Perspektif
Perspective

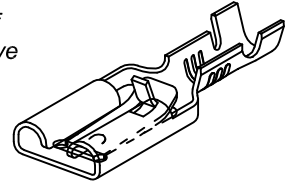

Kalıp çıkış yönü
Mold output direction

Makara açılım yönü
Reel opening direction

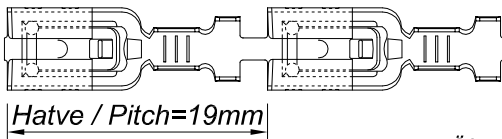

Hatve / Pitch=19mm

Ölçek
Scale : 2 / 1

Kablo Kesiti

Wire Section : 0.25 - 0.50 mm²

Resim üzerinden ölçü almayınız
do not measure on drawing

Tarih / Date	30.04.2018	İmza /Signature	Ölçek /Scale	02		
Çizen / Desing	T.Topçu			01		
Onay / Approval	S.Gölcük		5 / 1	No	Değişiklik / Revision	Tarih/Date



Parça Adı:
Part Name **KİLİTLİ DİŞİ FİŞ 4.8 KISA TİP M.A.**

Parça Kodu:
Part Code **TD 2166**